



**ROTARY
CYLINDER**

Double Rod Cylinder YW..R series

Best suited for HW-series chucks

- YW..R Built-in check valve and pressure relief valve
- YW..RE Built-in check valve, pressure valve and sensor switches

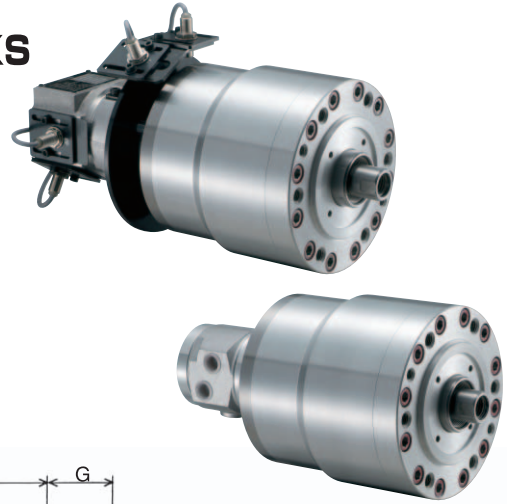

Dimensional Drawings

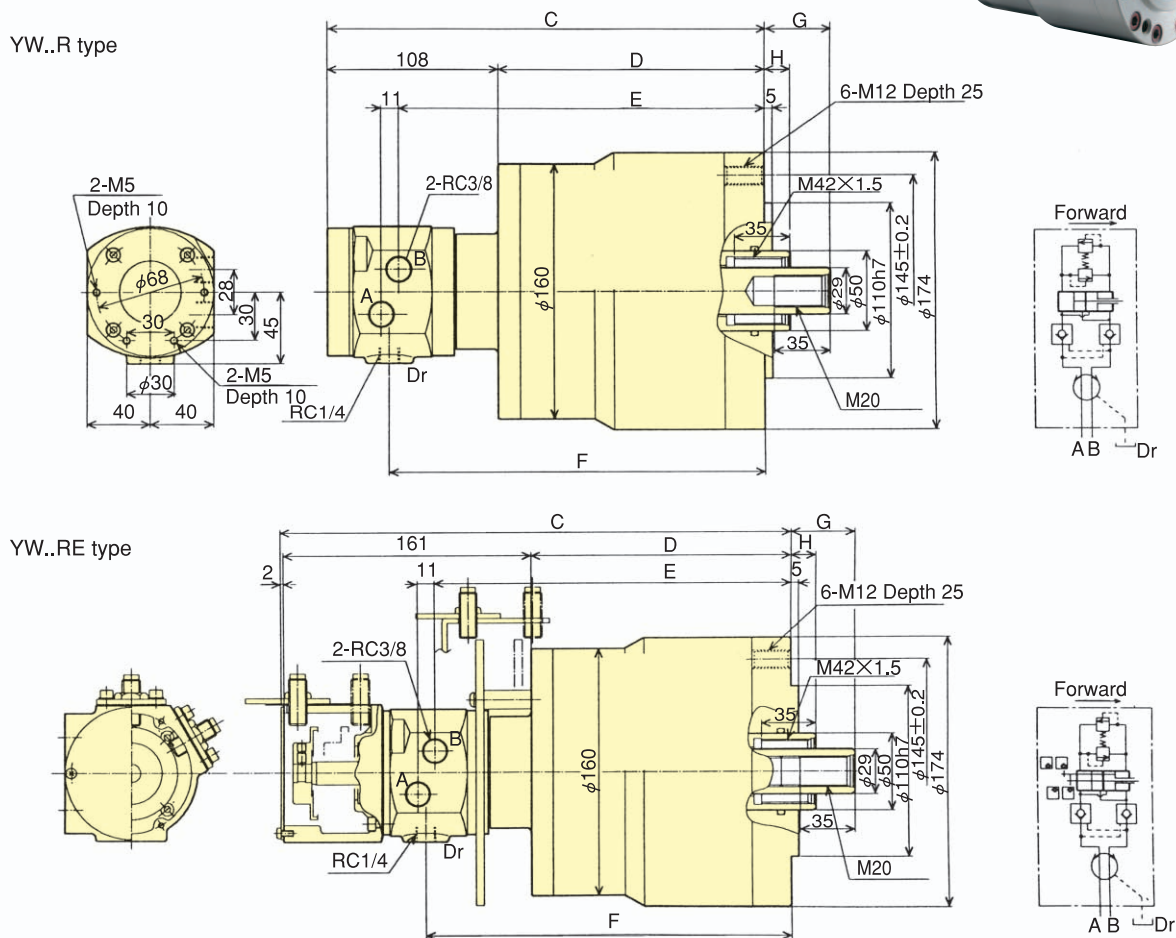

Dimensions

| Model | Dimensions | | | | | | | | | |
|----------|------------|----|-----|-----|-----|-----|--------|--------|--------|--------|
| | A | B | C | D | E | F | G max. | G min. | H max. | H min. |
| YW1220R | 20 | 20 | 276 | 168 | 231 | 237 | 61 | 41 | 36 | 16 |
| YW1225R | 25 | 25 | 286 | 178 | 241 | 247 | 56 | 31 | 36 | 11 |
| YW1220RE | 20 | 20 | 331 | 168 | 231 | 237 | 61 | 41 | 36 | 16 |
| YW1225RE | 25 | 25 | 341 | 178 | 241 | 247 | 56 | 31 | 36 | 11 |

Specifications *Draw bar pull force : Pressure 3.0MPa (30.6kgf/cm²) *Total leakage : 3.0MPa (30.6kgf/cm²) and oil temperature 50°C.

| Model | Piston stroke mm | Piston Area | | Piston Area | | Max. Operation Pressure MPa (kgf/cm ²) | Total leakage ℓ/min | Max. Speed min ⁻¹ (r.p.m) | Weight kg | Moment of inertia kg·m ² |
|----------|---------------------|---------------------------|---------------------------|-------------------|-------------------|---|------------------------|---|--------------|--|
| | | Push Side cm ² | Pull Side cm ² | Push Side kN(kgf) | Pull Side kN(kgf) | | | | | |
| YW1220R | 20 | 126 | 113 | 33 (3365) | 31 (3161) | 3.0 (30.6) | 0.7 | 5000 | 15.3 | 0.043 |
| YW1225R | 25 | 126 | 113 | 33 (3365) | 31 (3161) | 3.0 (30.6) | 0.7 | 5000 | 15.5 | 0.044 |
| YW1220RE | 20 | 123 | 113 | 32 (3263) | 31 (3161) | 3.0 (30.6) | 0.7 | 5000 | 16.3 | 0.044 |
| YW1225RE | 25 | 123 | 113 | 32 (3263) | 31 (3161) | 3.0 (30.6) | 0.7 | 5000 | 16.5 | 0.045 |